

# PSA PEUGEOT CITROËN

## Petrol Engine Setting & Locking Set – BMW/PSA

### 9AT1010E

- The set includes camshaft setting tool, crankshaft locking pin & chain tensioner tool
- Suitable for BMW Mini and PSA Peugeot Citroën 1.4/1.6 16v valvetronic direct injection engines
- Use to lock and adjust engine timing



2384 1 / 5

**Citroen**  
C4(08-11)  
C4 Picasso(08-13)  
**Peugeot**  
MODEL: 207(06-11)  
207CC(07-14)  
308(07-14)  
3008(09-12)  
5008(09-11)

**Citroen**  
8FR(EP3)  
5FS(EP6)  
**Peugeot**  
ENGINE CODE: EP3(8FS)  
EP6(5FW)  
EP6DT(5FX)  
8FS(EP3)  
EP6DTS(5FY)

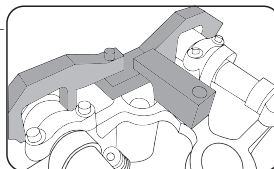

#### CONTENTS :

- A – camshaft setting tool (inlet)
- B – camshaft setting tool (exhaust)
- C – camshaft setting tool
- D – camshaft setting clamp
- E – crankshaft locking pin
- F – chain tensioner tool
- G – M10 screw\*4

# PSA PEUGEOT CITROËN

## Petrol Engine Timing Set

### 9AT1021E

- The set includes special flywheel tools and cam/ crankshaft timing pin
- Use to replace timing belt engines of:  
1.0 / 1.1 / 1.4 / 1.6 / 1.6VTS / 1.8 16v / 2.0 / 2.0 16V / 2.2
- Include PSA "EW coded" twin-cam 16v engine and HPI versions
- Suitable for PSA Peugeot / Citroen engines

2164 1 / 10

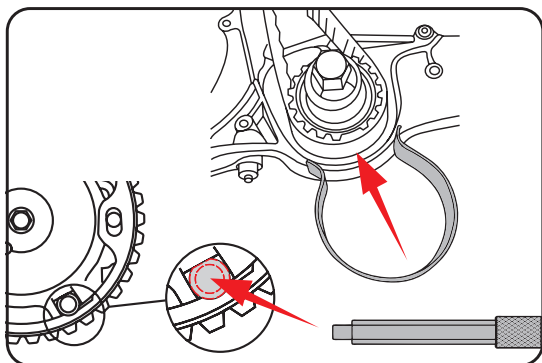

#### CONTENTS :

- A – timing belt retaining tool
- B – tensioner adjusting tool
- C – flywheel locking tool
- D – flywheel holding tool
- E – flywheel plate locking tool
- F – flywheel locking tool
- G – flywheel locking tool
- H – tensioner locking tool
- I – tensioner locking tool
- J – timing pin

