

Mini Ratchet Set

1001MR

1/4"

- Mini ratchet set
- 5° gear action degree (72 teeth)
- Two teeth pawl action

10
PC.



Contents 0.19 6 / 36

	1025P	PH1, PH2
	1025T	T10, T15, T20
	1025H	H3, H4, H5, H6
	2765-04G	

2515MR

1/4"

- Mini ratchet set
- 5° gear action degree (72 teeth)
- Two teeth pawl action

15
PC.



Contents 0.26 6 / 36

	2335M	5, 5.5, 6, 7, 8
	1025P	PH1, PH2
	1025T	T10, T15, T20
	1025H	H3, H4, H5, H6
	276A-04G	

2501MR

1/4"

- 5° gear action degree (72 teeth)
- Two teeth pawl action

21
PC.



Contents 0.36 4 / 48

	2335M	4, 5, 6, 7, 8, 9, 10, 11, 12, 13
	1025P	PH1, PH2, PH3
	1025T	T10, T20, T30
	1025H	H4, H6
	1025S	5.5x1.0, 6.5x1.2
	276A-04G	

Accessory

2745

1/4"

- Palm ratchet bit holder
- Non-toothed palm ratchet is designed for any angle of degree
- 3 position of forward / lock / reverse
- Suitable for narrow space where a standard wrench cannot attain
- Anodized aluminum alloy body & chrome vanadium alloy steel bit holder

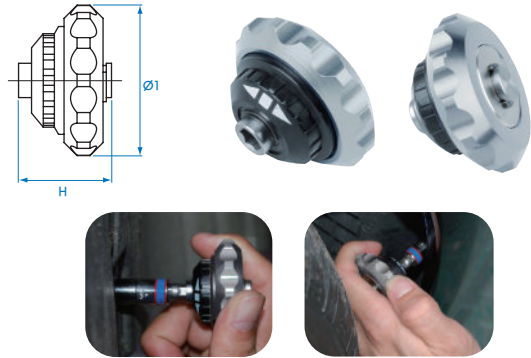

KT NO.	Ø1 mm	H		
2745	46	26.5	103	12 / 144

- Material - chrome vanadium alloy steel
- Finishing - polished, chrome plated

KT No. & D1

2221

1/4"

- Extension bar
- DIN 3122



KT NO.	Overall length inch	mm		
2221-02	2	55	27	30 / 480
2221-03	3	75	36	20 / 400
2221-04	4	100	44	15 / 240
2221-06	6	150	67	15 / 240
2221-10	10	254	107	15 / 240
2221-12	12	305	130	15 / 240



CAUTION In order to get normal life of bit socket, Always use within limited torque to bit.

2223

1/4"

- Offset extension bar
- Max. torque: 35 Nm
- DIN 3123



KT NO.	Overall length inch	mm		
2223-02	2	55	24	30 / 480
2223-04	4	100	44	15 / 240